

Technical
Product Specifications:

STRUT

Approval/calculation possibilities:

- AS/NZS 4600:2018
- NZS 4100:2020
- NZS1170.5:2009
- NZS 4219:2009
- NZS 4541:2020
- AS/NZS 4680:2006



FDG STRUT

Strut is one of the core components of building service systems, this includes the Mechanical, Electrical, Plumbing and Fire Sprinkler trades. This light weight product supports heavy loads ideal for supporting cable trays, pipework, building services equipment, ceiling support grids and seismic bracing for all non-structural building.

Strut is a time and money saving alternative to traditional support methods by eliminating the need for welding and drilling. It also provides superior flexibility due to its modular nature. With varying levels of corrosion resistant available, product and documentation can be supplied to suit the specific requirements of a project.

Simple to install, FDG Strut can be used for supports in applications where space is limited.

FDG offers a full range of strut with over 40 different sizes/finishes and configurations, along with 200+ fittings available in stock to service any site conditions you may encounter.

Advantages of using FDG STRUT

- Saves you time and money.
 - Supports heavy loads.
 - Lightweight design.
 - No need for welding or drilling.
 - Corrosion Resistant.
 - Simple and easy to install.
 - Huge range of sizes, finishings and fittings.
-

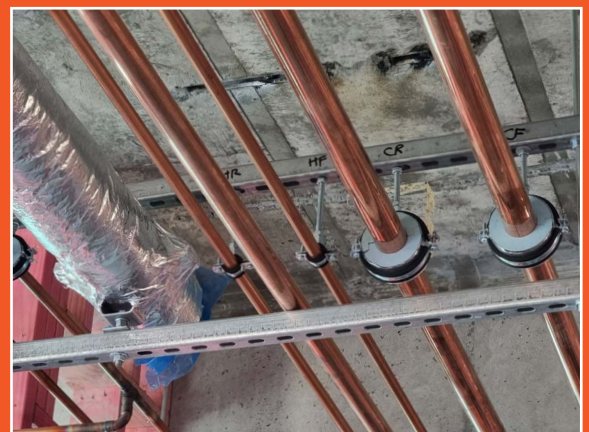

■ Contents

Engineering Notes for Strut Tables

- Loads shown in the engineering tables are calculated in accordance with AS/NZS 4600:2018 Cold-formed Steel Structures.
- Allowable loads calculated from ultimate loads divided by 1.5. (Safety factor of 1.5.)
- The guaranteed minimum yield stress F_y has been taken as 264 MPa for Strut, and the increase allowed resulting from cold forming has been using AS/NZD 4600.
- Beam load (and resulting deflection) are applied to a simply supported span (without full lateral restraint), about the Y-Y axis only.
- Beam self weight has been considered, the load provided is the additional allowable load that may be applied.
- Concentric column load is axially applied at centroid.

FDG1000

Solid Strut Channel

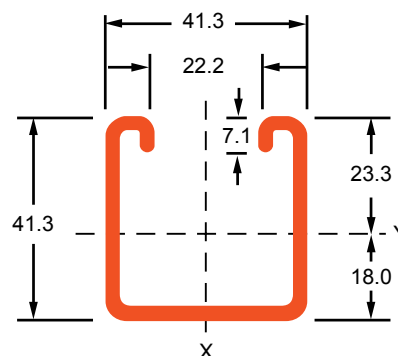
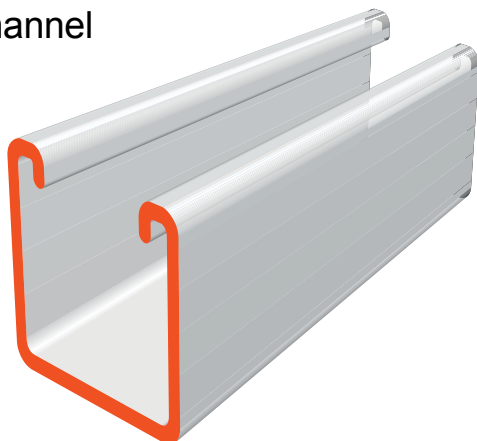

FDG1000					
 Span (mm)	Simply Supported Beam				Column
	 Uniform Distributed Load		 Point Load		 Concentric Axial Load
	Allowable Load (kN)	Deflection (mm)	Allowable Load (kN)	Deflection (mm)	Allowable Load (kN)
200	15.41	0.11	8.82	0.10	46.4
400	9.06	0.52	4.76	0.44	40.2
600	6.28	1.22	3.18	0.99	33.6
800	4.75	2.18	2.41	1.77	26.8
1000	3.82	3.43	1.91	2.74	21.4
1200	3.21	4.98	1.59	3.94	17.4
1400	2.76	6.79	1.38	5.45	14.6
1600	2.39	8.79	1.21	7.09	12.3
1800	2.13	11.14	1.06	8.87	10.6
2000	1.92	13.77	0.97	11.15	9.5
2200	1.76	16.82	0.88	13.49	8.1
2400	1.61	19.96	0.79	15.76	7.5
2600	1.48	23.40	0.74	18.55	6.6
2800	1.38	27.25	0.68	21.32	5.8
3000	1.29	31.21	0.65	25.08	-

FDG1000							
Section Properties		Y-Y Axis			X-X Axis		
Weight kg/m	Area of Section mm ²	Moment of Inertia I 10 ⁶ mm ⁴	Sectional Modulus Z 10 ³ mm ⁴	Radius of Gyration r mm	Moment of Inertia I 10 ⁶ mm ⁴	Sectional Modulus Z 10 ³ mm ⁴	Radius of Gyration r mm
2.60	331	0.070	3.052	14.5	0.092	4.448	16.6

FDG1000		
Thickness	Material	Finish
2.5mm	Mild Steel, Minimum Yield strength $F_y = 235\text{MPa}$ Minimum Tensile strength $F_u = 370\text{MPa}$	Plain, Pre Galvanised (Z275), Hot Dip Galvanised (55 μm), SS316 Stainless Steel. (Other finishes or coatings available on request e.g. Power Coated)

FDG1000T

Slotted Strut Channel

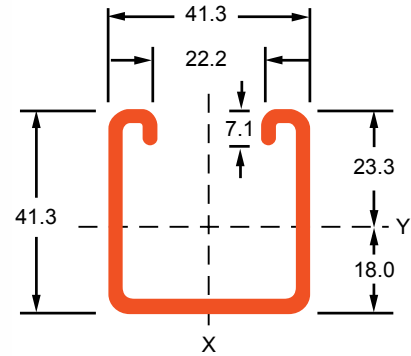
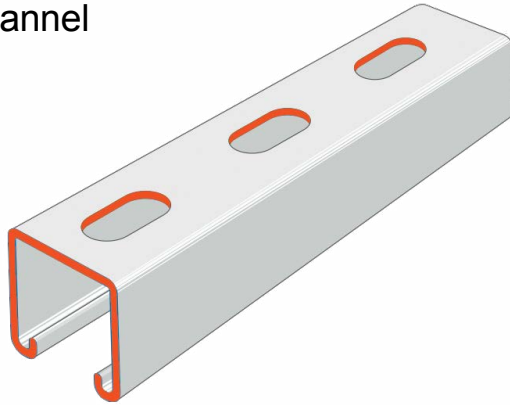

*14mm x 30mm holes at 50mm centers

FDG1000T					
 Span (mm)	Simply Supported Beam				Column
	 Uniform Distributed Load		 Point Load		 Concentric Axial Load
	Allowable Load (kN)	Deflection (mm)	Allowable Load (kN)	Deflection (mm)	Allowable Load (kN)
200	13.24	0.10	7.41	0.09	42.4
400	7.41	0.43	3.82	0.35	36.4
600	5.08	0.99	2.56	0.79	30.1
800	3.81	1.75	1.94	1.43	24.2
1000	3.06	2.74	1.55	2.23	19.1
1200	2.58	3.99	1.29	3.21	15.7
1400	2.19	5.39	1.11	4.38	13.0
1600	1.93	7.09	0.97	5.71	11.1
1800	1.73	9.03	0.85	7.14	9.6
2000	1.55	11.15	0.78	8.92	8.3
2200	1.40	13.35	0.71	10.79	7.4
2400	1.28	15.94	0.65	12.84	6.7
2600	1.19	18.81	0.59	14.99	5.9
2800	1.09	21.41	0.55	17.43	5.2
3000	1.02	24.80	0.52	20.07	-

FDG1000T							
Section Properties		Y-Y Axis			X-X Axis		
Weight kg/m	Area of Section mm ²	Moment of Inertia I 10 ⁶ mm ⁴	Sectional Modulus Z 10 ³ mm ⁴	Radius of Gyration r mm	Moment of Inertia I 10 ⁶ mm ⁴	Sectional Modulus Z 10 ³ mm ⁴	Radius of Gyration r mm
2.41	298	0.060	2.756	14.2	0.091	4.415	17.5

FDG1000T		
Thickness	Material	Finish
2.5mm	Mild Steel, Minimum Yield strength $F_y = 235\text{MPa}$ Minimum Tensile strength $F_u = 370\text{MPa}$	Plain, Pre Galvanised (Z275), Hot Dip Galvanised (55µm), SS316 Stainless Steel. (Other finishes or coatings available on request e.g. Power Coated)

FDG3300

Solid Strut Channel

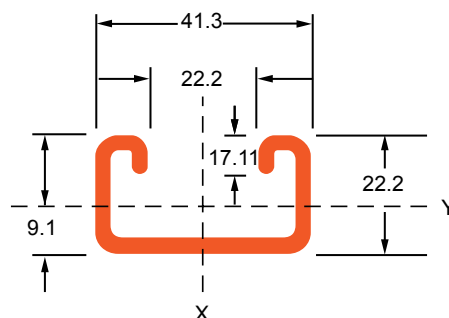
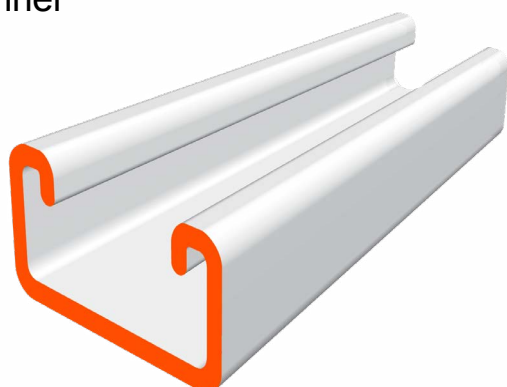

FDG3300					
 Span (mm)	Simply Supported Beam				Column
	 Uniform Distributed Load		 Point Load		 Concentric Axial Load
	Allowable Load (kN)	Deflection (mm)	Allowable Load (kN)	Deflection (mm)	Allowable Load (kN)
200	5.71	0.22	3.29	0.18	36.3
400	3.29	1.02	1.71	0.74	30.6
600	2.26	2.38	1.12	1.64	24.4
800	1.72	4.26	0.85	2.97	17.9
1000	1.38	6.70	0.68	4.60	12.2
1200	1.15	9.72	0.56	6.57	8.8
1400	0.99	13.26	0.49	9.23	6.5
1600	0.87	17.15	0.44	12.13	4.7
1800	0.77	21.74	0.38	15.17	-
2000	0.69	26.87	0.35	18.89	-
2200	0.62	32.82	0.31	22.59	-
2400	0.58	38.97	0.29	27.11	-
2600	0.54	45.67	0.26	31.66	-
2800	0.49	53.19	0.25	36.91	-
3000	0.46	60.92	0.23	42.15	-

FDG3300							
Section Properties		Y-Y Axis			X-X Axis		
Weight kg/m	Area of Section mm ²	Moment of Inertia I 10 ⁶ mm ⁴	Sectional Modulus Z 10 ³ mm ⁴	Radius of Gyration r mm	Moment of Inertia I 10 ⁶ mm ⁴	Sectional Modulus Z 10 ³ mm ⁴	Radius of Gyration r mm
1.84	234	0.014	1.085	7.7	0.056	2.675	15.4

FDG3300		
Thickness	Material	Finish
2.5mm	Mild Steel, Minimum Yield strength $F_y = 235\text{MPa}$ Minimum Tensile strength $F_u = 370\text{MPa}$	Plain, Pre Galvanised (Z275), Hot Dip Galvanised (55 μm), SS316 Stainless Steel. (Other finishes or coatings available on request e.g. Power Coated)

FDG3300T

Slotted Strut Channel

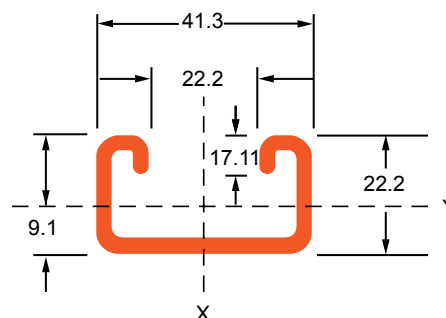
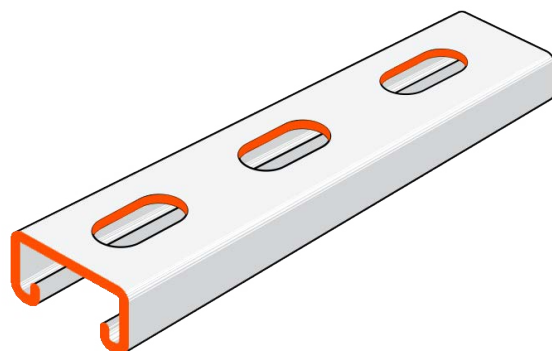

*14mm x 30mm holes at 50mm centers

FDG3300T					
	Simply Supported Beam				Column
	 Uniform Distributed Load		 Point Load		 Concentric Axial Load
	Allowable Load (kN)	Deflection (mm)	Allowable Load (kN)	Deflection (mm)	Allowable Load (kN)
200	4.82	0.21	2.68	0.18	32.6
400	2.68	0.91	1.38	0.75	27.4
600	1.82	2.09	0.92	1.70	22.0
800	1.36	3.71	0.69	3.02	16.2
1000	1.10	5.85	0.55	4.70	10.8
1200	0.92	8.49	0.46	6.74	7.8
1400	0.79	11.53	0.39	9.20	5.8
1600	0.70	15.17	0.35	12.09	4.2
1800	0.61	19.04	0.31	15.17	-
2000	0.55	23.52	0.28	18.81	-
2200	0.50	28.57	0.25	22.91	-
2400	0.45	33.20	0.23	26.98	-
2600	0.43	40.01	0.21	31.66	-
2800	0.40	46.13	0.19	36.25	-
3000	0.37	53.19	0.18	41.88	-

FDG3300T							
Section Properties		Y-Y Axis			X-X Axis		
Weight kg/m	Area of Section mm ²	Moment of Inertia I 10 ⁶ mm ⁴	Sectional Modulus Z 10 ³ mm ⁴	Radius of Gyration r mm	Moment of Inertia I 10 ⁶ mm ⁴	Sectional Modulus Z 10 ³ mm ⁴	Radius of Gyration r mm
1.68	198	0.012	9.874	7.6	0.055	2.658	16.5

FDG3300T		
Thickness	Material	Finish
2.5mm	Mild Steel, Minimum Yield strength $F_y = 235\text{MPa}$ Minimum Tensile strength $F_u = 370\text{MPa}$	Plain, Pre Galvanised (Z275), Hot Dip Galvanised (55 μm), SS316 Stainless Steel. (Other finishes or coatings available on request e.g. Power Coated)

FDG5500

Solid Strut Channel

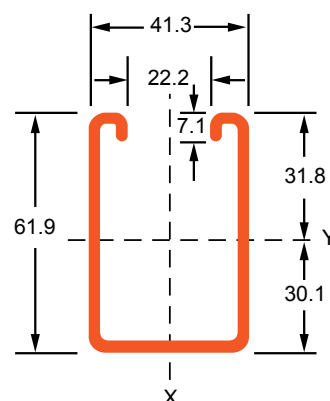
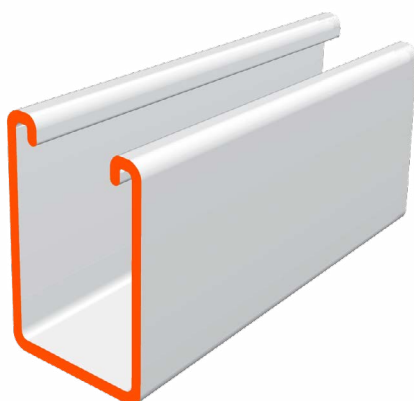

FDG5500					
 Span (mm)	Simply Supported Beam				Column
	 Uniform Distributed Load		 Point Load		 Concentric Axial Load
	Allowable Load (kN)	Deflection (mm)	Allowable Load (kN)	Deflection (mm)	Allowable Load (kN)
200	28.06	0.08	17.06	0.07	59.2
400	17.18	0.38	9.12	0.32	50.3
600	12.00	0.88	6.18	0.71	41.1
800	9.18	1.58	4.65	1.29	31.6
1000	7.38	2.49	3.71	1.99	22.9
1200	6.21	3.61	3.12	2.86	18.4
1400	5.32	4.92	2.68	3.95	15.2
1600	4.67	6.37	2.32	5.14	12.8
1800	4.16	8.07	2.09	6.43	11.1
2000	3.74	9.98	1.88	8.08	10.0
2200	3.40	12.19	1.71	9.78	8.9
2400	3.12	14.47	1.56	11.43	8.1
2600	2.86	16.96	1.44	13.45	7.4
2800	2.68	19.76	1.34	15.46	6.9
3000	2.51	22.63	1.25	18.18	6.4

FDG5500							
Section Properties		Y-Y Axis			X-X Axis		
Weight kg/m	Area of Section mm ²	Moment of Inertia I 10 ⁶ mm ⁴	Sectional Modulus Z 10 ³ mm ⁴	Radius of Gyration r mm	Moment of Inertia I 10 ⁶ mm ⁴	Sectional Modulus Z 10 ³ mm ⁴	Radius of Gyration r mm
3.41	434	0.199	5.854	21.4	0.131	6.324	17.3

FDG5500		
Thickness	Material	Finish
2.5mm	Mild Steel, Minimum Yield strength $F_y = 235\text{MPa}$ Minimum Tensile strength $F_u = 370\text{MPa}$	Plain, Pre Galvanised (Z275), Hot Dip Galvanised (55 μm), SS316 Stainless Steel. (Other finishes or coatings available on request e.g. Power Coated)

FDG5500T

Slotted Strut Channel

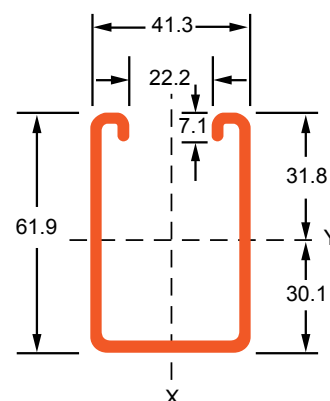
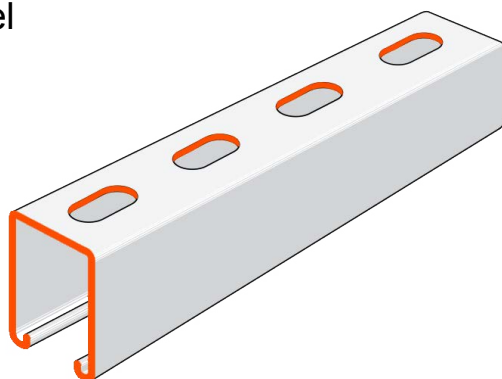

*14mm x 30mm holes at 50mm centers

FDG5500T					
	Simply Supported Beam				Column
	 Uniform Distributed Load		 Point Load		 Concentric Axial Load
	Allowable Load (kN)	Deflection (mm)	Allowable Load (kN)	Deflection (mm)	Allowable Load (kN)
200	24.47	0.07	14.18	0.07	53.4
400	14.12	0.34	7.35	0.28	45.3
600	9.71	0.78	4.97	0.64	37.1
800	7.39	1.40	3.74	1.13	28.7
1000	5.88	2.18	3.00	1.78	21.4
1200	4.94	3.17	2.50	2.56	16.8
1400	4.28	4.36	2.15	3.50	13.7
1600	3.72	5.65	1.88	4.58	11.6
1800	3.34	7.21	1.67	5.78	10.0
2000	3.00	8.90	1.50	7.12	8.9
2200	2.72	10.73	1.35	8.55	8.0
2400	2.50	12.81	1.25	10.28	7.2
2600	2.29	14.96	1.15	12.03	6.8
2800	2.14	17.43	1.07	13.95	6.2
3000	1.99	19.97	1.00	16.02	5.8

FDG5500T							
Section Properties		Y-Y Axis			X-X Axis		
Weight kg/m	Area of Section mm ²	Moment of Inertia I 10 ⁶ mm ⁴	Sectional Modulus Z 10 ³ mm ⁴	Radius of Gyration r mm	Moment of Inertia I 10 ⁶ mm ⁴	Sectional Modulus Z 10 ³ mm ⁴	Radius of Gyration r mm
3.22	399	0.172	5.486	20.8	0.130	6.298	18.0

FDG5500T		
Thickness	Material	Finish
2.5mm	Mild Steel, Minimum Yield strength $F_y = 235\text{MPa}$ Minimum Tensile strength $F_u = 370\text{MPa}$	Plain, Pre Galvanised (Z275), Hot Dip Galvanised (55µm), SS316 Stainless Steel. (Other finishes or coatings available on request e.g. Power Coated)

FDG1001

Solid Strut Channel

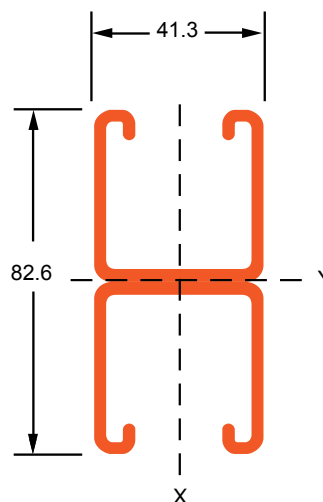
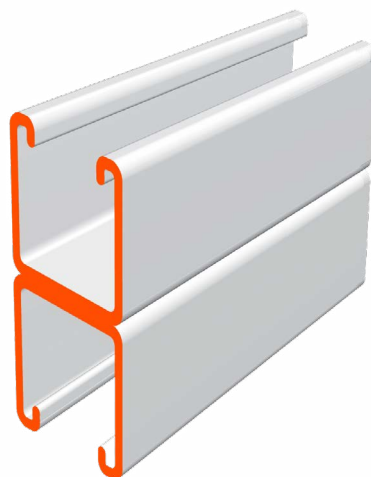

FDG1001					
 Span (mm)	Simply Supported Beam				Column
	 Uniform Distributed Load		 Point Load		 Concentric Axial Load
	Allowable Load (kN)	Deflection (mm)	Allowable Load (kN)	Deflection (mm)	Allowable Load (kN)
200	31.16	0.07	26.47	0.12	98.4
400	21.21	0.31	13.24	0.47	95.4
600	15.40	0.73	8.82	1.06	91.7
800	11.98	1.31	6.59	1.88	86.8
1000	9.63	2.06	5.29	2.95	80.9
1200	8.09	2.99	4.41	4.25	73.8
1400	7.03	4.08	3.76	5.77	66.6
1600	6.18	5.27	3.32	7.58	59.1
1800	5.53	6.68	2.94	9.57	51.6
2000	4.98	8.26	2.65	11.82	44.2
2200	4.53	10.09	2.41	14.33	37.3
2400	4.13	11.98	2.21	17.02	31.6
2600	3.81	14.04	2.03	19.91	26.8
2800	3.53	16.35	1.89	23.13	23.0
3000	3.31	18.73	1.76	26.59	21.1

FDG1001							
Section Properties		Y-Y Axis			X-X Axis		
Weight kg/m	Area of Section mm ²	Moment of Inertia I 10 ⁶ mm ⁴	Sectional Modulus Z 10 ³ mm ⁴	Radius of Gyration r mm	Moment of Inertia I 10 ⁶ mm ⁴	Sectional Modulus Z 10 ³ mm ⁴	Radius of Gyration r mm
5.20	662	0.343	8.216	22.8	0.184	8.894	16.7

FDG1001		
Thickness	Material	Finish
2.5mm	Mild Steel, Minimum Yield strength $F_y = 235\text{MPa}$ Minimum Tensile strength $F_u = 370\text{MPa}$	Plain, Pre Galvanised (Z275), Hot Dip Galvanised (55 μm), SS316 Stainless Steel. (Other finishes or coatings available on request e.g. Power Coated)

FDG1001

Slotted Strut Channel

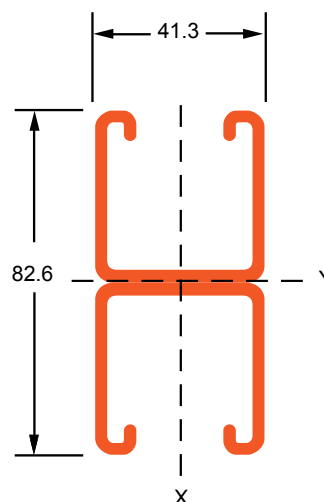
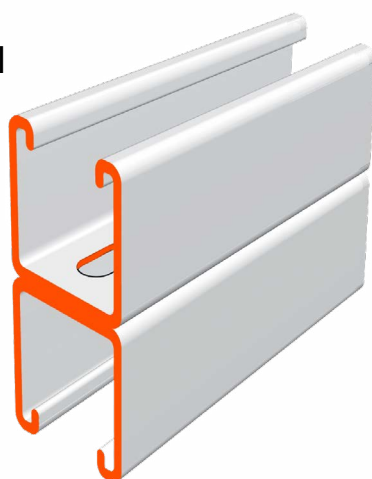

FDG1001					
 Span (mm)	Simply Supported Beam				Column
	 Uniform Distributed Load		 Point Load		 Concentric Axial Load
	Allowable Load (kN)	Deflection (mm)	Allowable Load (kN)	Deflection (mm)	Allowable Load (kN)
200	26.77	0.06	22.24	0.11	89.9
400	17.35	0.26	10.63	0.37	86.4
600	12.46	0.59	7.1	0.85	82.1
800	9.61	1.05	5.3	1.52	78.4
1000	7.71	1.65	4.29	2.4	72.2
1200	6.5	2.4	3.58	3.46	66.6
1400	5.58	3.24	3.02	4.64	59.3
1600	4.99	4.25	2.66	6.1	53.3
1800	4.49	5.41	2.36	7.7	46.7
2000	4.02	6.69	2.13	9.46	38.6
2200	3.6	8.01	1.94	11.46	34.1
2400	3.28	9.57	1.82	13.87	28.2
2600	3.06	11.29	1.62	16.09	24
2800	2.79	12.85	1.53	18.91	20.6
3000	2.62	14.88	1.41	21.28	18.9

FDG1001							
Section Properties		Y-Y Axis			X-X Axis		
Weight kg/m	Area of Section mm ²	Moment of Inertia I 10 ⁶ mm ⁴	Sectional Modulus Z 10 ³ mm ⁴	Radius of Gyration r mm	Moment of Inertia I 10 ⁶ mm ⁴	Sectional Modulus Z 10 ³ mm ⁴	Radius of Gyration r mm
4.82	596	0.294	7.419	22.3	0.182	8.828	17.6

FDG1001		
Thickness	Material	Finish
2.5mm	Mild Steel, Minimum Yield strength $F_y = 235\text{MPa}$ Minimum Tensile strength $F_u = 370\text{MPa}$	Plain, Pre Galvanised (Z275), Hot Dip Galvanised (55 μm), SS316 Stainless Steel. (Other finishes or coatings available on request e.g. Power Coated)

FDG5501
Solid Strut Channel

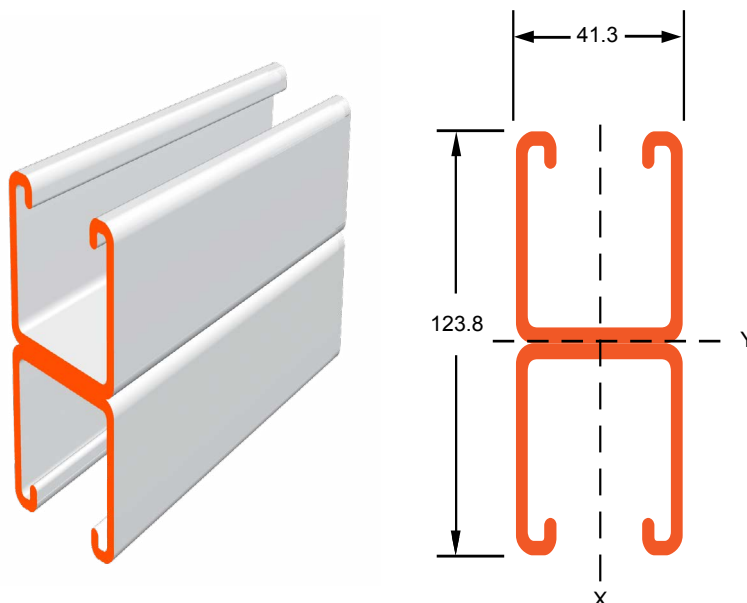

FDG5501					
 Span (mm)	Simply Supported Beam				Column
	 Uniform Distributed Load		 Point Load		 Concentric Axial Load
	Allowable Load (kN)	Deflection (mm)	Allowable Load (kN)	Deflection (mm)	Allowable Load (kN)
200	26.54	0.04	50.26	0.09	123.1
400	26.54	0.21	27.79	0.34	119.8
600	26.54	0.49	18.42	0.77	115.6
800	25.39	0.87	13.89	1.36	110.1
1000	20.87	1.37	11.05	2.14	103.6
1200	17.74	1.99	9.26	3.08	95.7
1400	15.22	2.72	7.89	4.18	87.3
1600	13.57	3.51	6.95	5.50	78.5
1800	12.13	4.45	6.18	6.94	69.6
2000	10.88	5.51	5.56	8.57	61.1
2200	9.95	6.73	5.03	10.39	52.6
2400	9.13	7.99	4.63	12.34	44.8
2600	8.48	9.36	4.28	14.43	38.1
2800	7.85	10.90	3.98	16.77	32.8
3000	7.37	12.48	3.71	19.28	28.4

FDG5501							
Section Properties		Y-Y Axis			X-X Axis		
Weight kg/m	Area of Section mm ²	Moment of Inertia I 10 ⁶ mm ⁴	Sectional Modulus Z 10 ³ mm ⁴	Radius of Gyration r mm	Moment of Inertia I 10 ⁶ mm ⁴	Sectional Modulus Z 10 ³ mm ⁴	Radius of Gyration r mm
6.74	870	1.072	17.458	35.2	0.261	12.662	17.4

FDG5501		
Thickness	Material	Finish
2.5mm	Mild Steel, Minimum Yield strength $F_y = 235\text{MPa}$ Minimum Tensile strength $F_u = 370\text{MPa}$	Plain, Pre Galvanised (Z275), Hot Dip Galvanised (55µm), SS316 Stainless Steel. (Other finishes or coatings available on request e.g. Power Coated)

sales@fdgnz.com

20 Mansel Dr, Warkworth, Auckland 0910 New Zealand

09-275-6811